

ROBERT DOEMEL, JR.
Highway Commissioner

901 W. COUNTY RD. Y, P.O. BOX 2764
OSHKOSH, WISCONSIN 54903-2764



OSHKOSH (920) 232-1700
FOX CITIES (920) 727-8640
FAX (920) 424-7790

Winnebago County
Highway Commission
The Wave of the Future

TO: Winnebago County Residents
SUBJECT: Mailboxes and Snow Plowing

Dear County Resident:

The Winnebago County Highway Department is charged with removing snow and ice accumulations from State, County and some Town roads throughout our County. Occasionally, mailboxes located within the road right of way can be difficult to avoid while plowing. County Highway employees are instructed to use as much caution as possible while plowing around mailboxes but despite our best efforts, sometimes damage does occur.

Mailboxes placed in the road right of way are the responsibility of the property owner. While the County is not legally required to replace mailboxes in the right of way that we damage, we do put up plain, standards boxes when it's evident that our equipment damaged the box.

I have enclosed a standard plan for a typical mailbox installation that may help prevent damage during snowplowing operations.

Please feel free to contact the Highway Department if you have any questions.

Thank you.

Sincerely,

A handwritten signature in black ink, appearing to read "Robert Doemel".

Robert Doemel, Commissioner
Winnebago County Highway Department

tests show that when more than two mailboxes are mounted together, some of the boxes can penetrate the passenger compartment. The use of a plank to mount several mailboxes is especially hazardous.

Guidelines for safe installation

It is best to keep the entire mailbox installation as light weight as possible. This permits a vehicle crashing into it to break off the mailbox with less damage to the vehicle. The heavier the installation, the less likely it will move instantaneously, causing more damage to the vehicle and injury to its occupants.

For safer mailboxes, follow four basic guidelines:

- Use support posts which will easily break off or move out of the way.
- Mount no more than two mailboxes on one support post.
- Attach the mailbox firmly to the support post using adequately strong bolts and plates.
- Consider roadside conditions in selecting a site.

Supports

The Postal Service requires that the bottom of the box be 42 to 48 inches above ground level. The following are recommended standards for supports which ensure that they will break away on impact:

- Pipes should be 1½ inch inside diameter or less.
- Square wood supports should not be larger than 4 inches by 4 inches nominal. Round wood posts should not be larger than 4 inches in diameter.
- Metal channel posts should not weigh more than 2 pounds per foot.
- Imbed supports no more than 24 inches into the ground and do not imbed them in concrete.
- Do not use anchor plates with metal posts. Anti-twist flanges are acceptable as long as they do not project more than 10 inches into the ground. These should be attached to the metal post or pipe with 2¾ inch (nominal) muffler clamps. The Federal Highway Administration has published *Accepted Safety Hardware*. For more information contact the State Division Office of the Federal Highway Administration.

Multiple installations

Mount no more than two mailboxes on a single support. Separate the supports a distance apart which equals three-quarters of the height of the post above ground (Figure 1). Thus boxes mounted four feet above ground should be at least three feet apart (post center to post

center). Figure 2 shows an alternate type multiple box system.

Support construction

Use U.S. Postal Service approved mailboxes. The AASHTO (American Association of State Highway and Transportation Officials) publication, *A Guide for Erecting Mailboxes on Highways*, contains detailed plans for mailbox assemblies and location. Insuring a firm mailbox-to-post attachment is one of the most important safety considerations.

Figures 3 and 4 show examples of a cantilever mailbox installation. While the cantilever design is helpful to snow removal operations it may cause the mailbox to impact a vehicle at the windshield. Raising the support arm height and firmly suspending the box below may be another way to lessen the windshield damage.

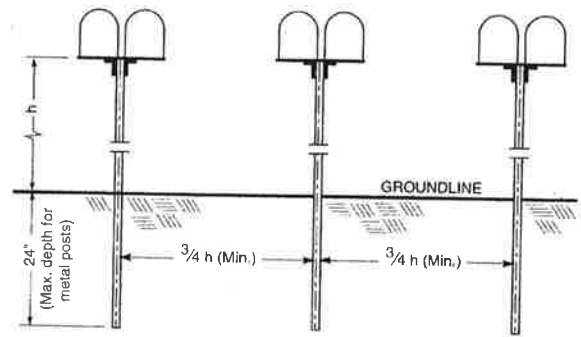

Figure 1: Spacing for multiple post installations

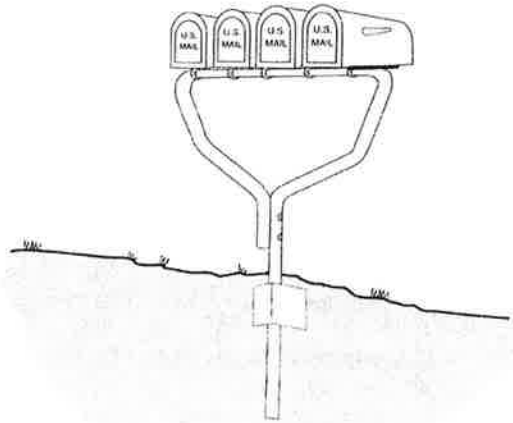

Figure 2: Suggested multiple box support system



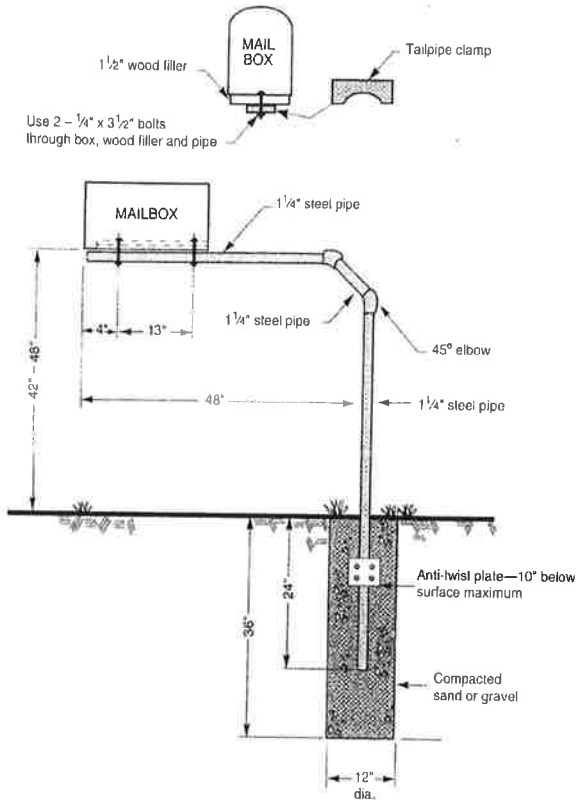

Figure 3: Example of a steel pipe cantilever mailbox support

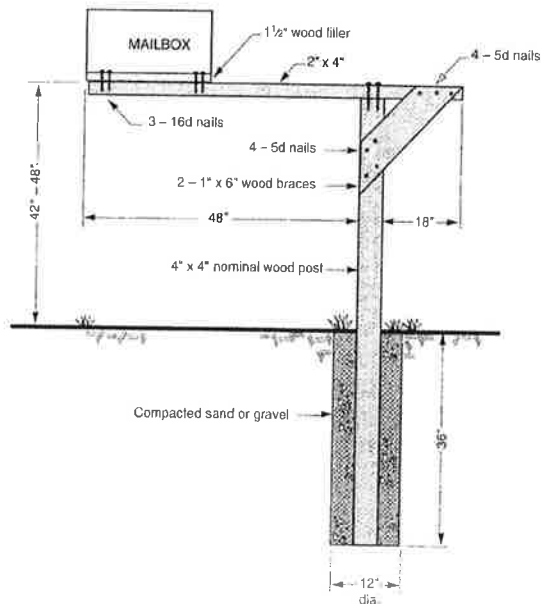

Figure 4: Example of a wood cantilever mailbox support

Siting mailboxes

In Wisconsin snow removal operations frequently conflict with mailboxes. Several local agencies have developed a standard for mailbox installations which has been successful in reducing the number of mailboxes damaged or demolished by snow plows. The standard is published in local papers (Figure 5).

They recommend placing the box on a 24-inch minimum arm, at a minimum height of 46 inches. The front of the box should be aligned with the outside edge of the shoulder.

Locating mailboxes along the roadside is complicated by many factors other than snow removal. These require balancing the maximum convenience to the patron with safety considerations for highway traffic, and with postal carrier convenience and safety. You must also take into account existing roadside conditions such as proximity to intersections; blind spots caused by curves, hills and vegetation; and utility poles, guardrails, nearby bridges, and other physical installations.

NOTICE

Recommended Mailbox Installations

To avoid damage to your mailbox and also allow the snowplows to remove the snow from under your mailbox, the following dimensions are recommended.

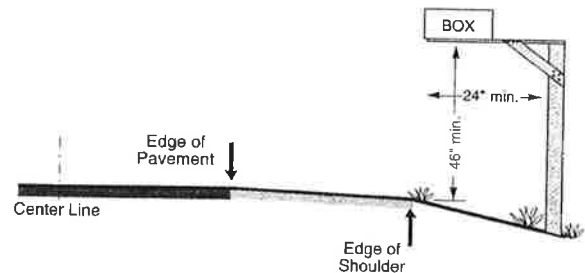

Placing mailboxes a short distance away from driveways and intersections helps to avoid vision-restricting snowbanks and also damage to your mailbox. The box and base should be strong enough to withstand flying snow and slush from traffic and snowplows.

By order of the _____
and with the approval of the U.S. Postal Service.

_____ Highway Commissioner

_____ Postmaster

Figure 5: Sample mailbox notice

